

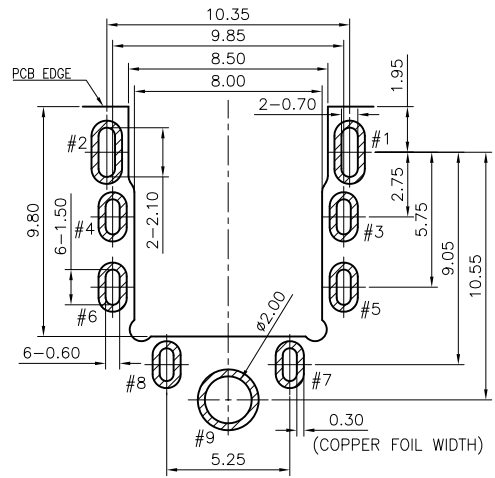

REV.	ECN NO OR DESCRIPTION	REVISED	DATE
0	PDR NO: APD1040290	MARK-C	2015.11.24

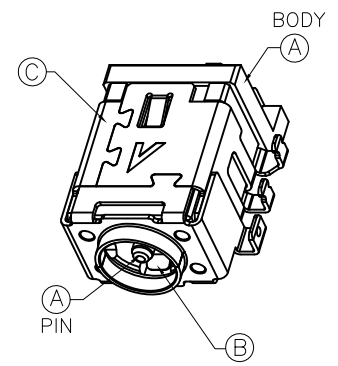
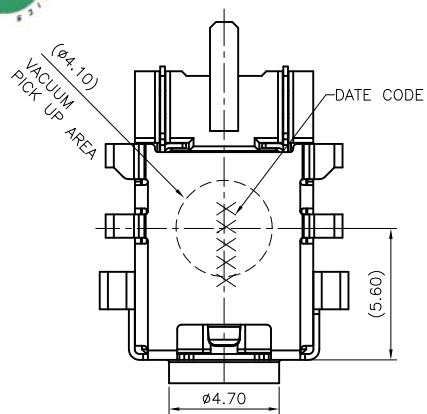

RECOMMENDED PCB LAYOUT (TOP VIEW)
(TOLERANCE=±0.05mm ; THICKNESS=1.0t)

- NOTES:
- MATERIAL: SEE TABLE
PLATING: TERMINAL: GOLD PLATED ON CONTACT AREA, AND MATTE-TIN 60~150u" ON SOLDER AREA
SHELL: NICKEL PLATED 60u"MIN.
 - THE CAVITY, LOGO MAX HEIGHT 0.10mm ABOVE SURFACE. THE TEXT HEIGHT IS ABOUT 1mm.
 - IF ANY DIMENSIONS OR DRAFT ANGLES WEREN'T MARKED, PLS. REFER TO 3D DRAWING
 - ELECTRICAL CHARACTERISTICS:
 - RATING: 20V 5A
 - CONTACT RESISTANCE: INITIAL 10mΩ MAX; AFTER 15mΩ MAX
 - DIELECTRIC WITHSTANDING VOLTAGE: 500V AC FOR ONE MINUTE
 - INSULATION RESISTANCE: 100MΩ MIN. MEASURED BY 500 VDC
 - MECHANICAL CHARACTERISTICS:
 - INSERTION FORCE: 0.8~2.0kg. (INITIAL & AFTER LIFE TEST)
 - WITHDRAWAL FORCE: 0.8~2.0kg. (INITIAL & AFTER LIFE TEST)
 - LIFE TEST: 8,000 CYCLES MIN
 - SPEC. PLS. REFER TO SPEC-58901-XXXX-XXX
 - PACKAGE PLS. REFER TO 58904-002XX-XXX-PCK
 - PART NUMBER:

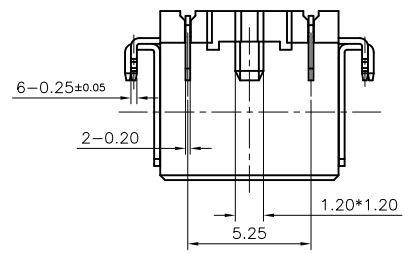
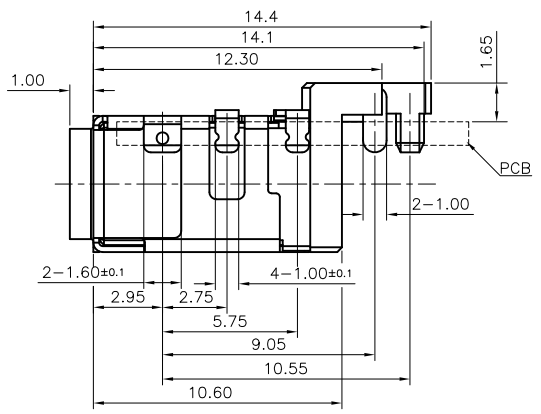
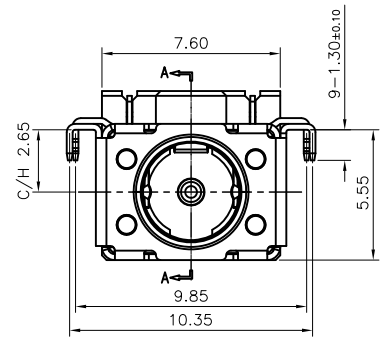

58922-002 0 2 -001

CKT

001: NONE

PLATING:
2: GOLD FLASH

PACKING:
0: TAPE & REEL

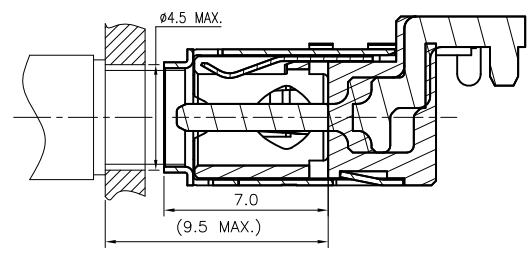
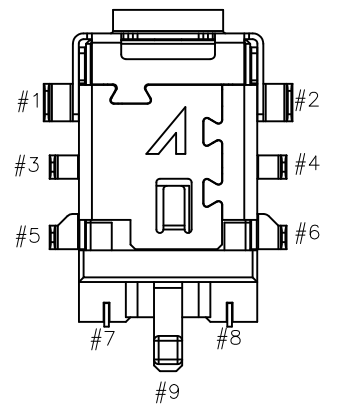
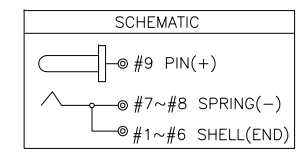

REFERENCE MATING DRAWING

C	SHELL	1	SUS304-1/2H, 0.25T	NICKEL PLATED
B	SIGNAL	1	C5210-EH, 0.2T	TIN PLATED
A	INSERT MOLDING	1	PIN:C2680-H, 1.2T	GOLD FLASH
		1	BODY:PA4T+30%GF UL94V-0	BLACK
NO	DESCRIPTION	Q'TY	MATERIAL	PLATING & COLOR

宏致電子股份有限公司
Aces Electronics Co.,Ltd.

品名 (TITLE): 4ø DC POWER JACK (CH:-2.65)

製圖 (DR): '15/11/24 MARK-C

審核 (CHKD): BRUCE

圖號 (DWG NO.): 58922-00202-001

核准 (APPD): JACK

表面處理 (FINISH):

比例 (SCALE): 3.2:1

單位 (UNITS): mm

張數 (SHEET): 1 OF 2

SIZE: A4

REV: 0

檢驗尺寸標示

SYMBOLS ① ② INDICATE CLASSIFICATION DIMENSION

① MARK IS CRITICAL DIM.

② MARK IS MAJOR DIM.



1. 負極接觸狀態

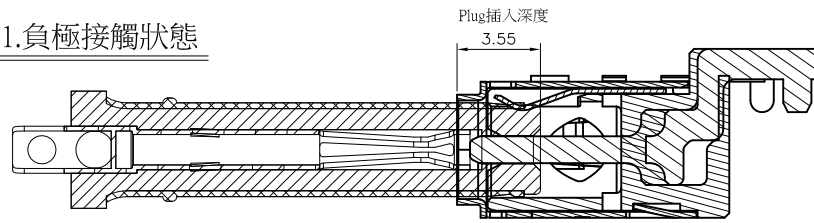

2. 正極接觸狀態

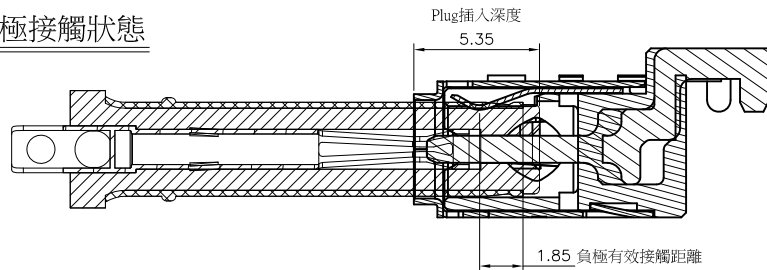

3. Lock狀態

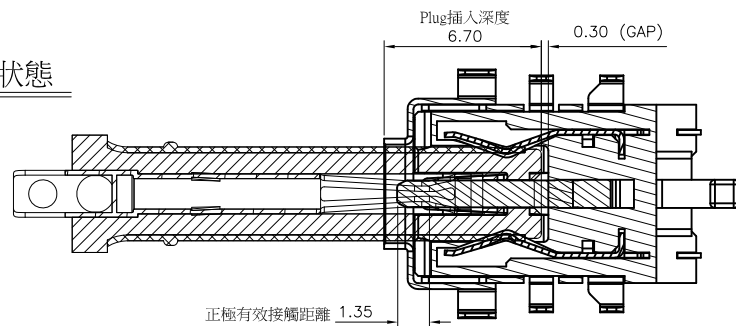

4. Plug插到底狀態

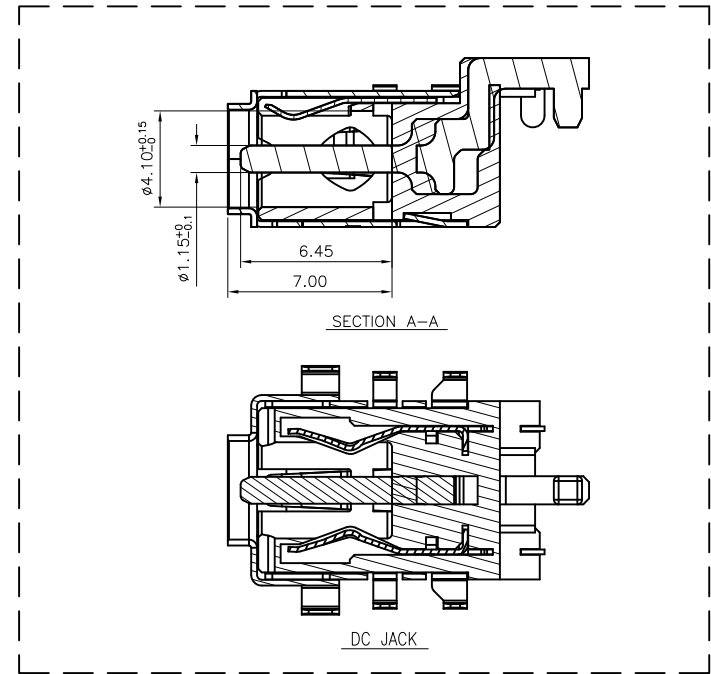
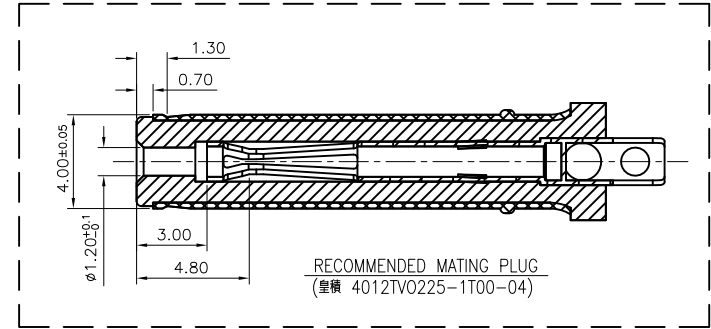
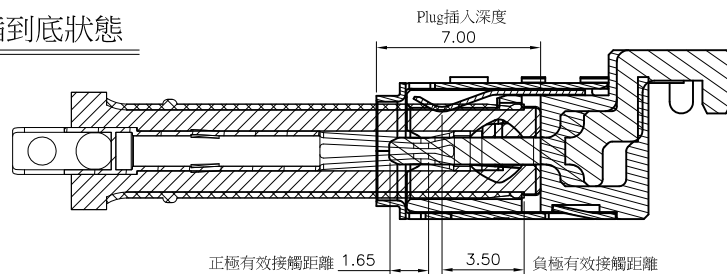

一般公差 TOLERANCES X ±0.5 XX ±0.15 X ±0.25 .XXX ±0.1 ANGLES ±2°		宏致電子股份有限公司 Aces Electronics Co.,Ltd.	
檢驗尺寸標示 SYMBOLS INDICATE CLASSIFICATION DIMENSION	品名 (TITLE) 4φ DC POWER JACK (CH:-2.65)	製圖 (DR) '15/11/24 MARK-C	審核 (CHKD) BRUCE
MARK IS CRITICAL DIM. MARK IS MAJOR DIM.	圖號 (DWG NO.) 58922-00202-001	核准 (APPD) JACK	張數 (SHEET) 2 OF 2
表面處理 (FINISH)	比例 (SCALE) 3.2:1	單位 (UNITS) mm	圖號 (DWG NO.)
		尺寸 (SIZE) A4	版次 (REV) 0